

---

---

# TRIPLE DECKERS

A Publication of The New Haven Preservation Trust

---

---



## INTRODUCTION

During the past decade, interest in older residential buildings in Connecticut's urban neighborhoods has experienced a great revival. Urban renewal programs of the 1950s and 1960s, which typically categorized old buildings as obsolete liabilities best dealt with through demolition, have gradually given way to revitalization programs focusing on the rehabilitation of older buildings. This change in attitude has been fostered by a number of factors, including an increasing recognition that (a) older residential buildings make an important contribution to the special "historic" character of a city and its neighborhoods; (b) buildings of this type often exhibit a level of excellence in craftsmanship which is rarely found in modern buildings; and (c) rehabilitation of older residential buildings is increasingly becoming an affordable and productive investment for homeowners and developers alike.

This brochure has been prepared by the New Haven Preservation Trust in cooperation with the City of New Haven and the Connecticut Historical Commission in order to describe the more distinctive architectural and historical characteristics of one of Connecticut's most common turn-of-the-century residential building types: the Triple Decker. It is also designed to provide Triple Decker owners with basic guidelines relating to the effective maintenance and rehabilitation of their buildings.

## WHAT IS A TRIPLE DECKER?

In its purest form, a Triple Decker is a narrow, freestanding, 3-story, rectangular wooden box containing a stack of three, virtually identical apartments accessed by common front and rear stairwells. Triple deckers display a broad range of variations on this basic theme. Some have gable roofs, others have gambrel roofs; some have projecting window bays, others do not; some have 3-story porches, others have 1- or 2-story porches; some are built of brick, others of concrete block; some are paired versions, essentially two Triple Deckers built side by side and sharing a common bearing wall. These are commonly known as "Perfect Sixes."

While found in other parts of the country, the Triple Decker is predominantly a New England building type. It is also an urban housing form; its narrow and deep proportions cater to the narrow and deep lots found in most inner-city neighborhoods.

## HISTORICAL BACKGROUND

From the late 1880s through the end of World War I, Triple Deckers were constructed in extensive numbers, often in groups of five or more, in many of the state's urban centers. New Haven, Waterbury, Bridgeport, and Hartford share the majority of these structures. In New Haven, Triple Deckers are found on

scattered sites throughout the Hill, Newhallville, Dixwell, Dwight, and Fair Haven neighborhoods. Triple Deckers were immensely popular between the 1880s and the 1920s for several reasons. Contractors and developers found them relatively quick and inexpensive to build. Called "hurry-up housing," the roomy, well-lit interiors and the affordable prices were especially attractive to the working families that were swelling Connecticut's industrial centers.

Triple Deckers proved particularly popular among the southern and eastern European immigrant families who settled in Connecticut around the turn of the century. They not only featured apartments big enough to accommodate immediate family members in reasonable comfort; they also allowed in their multiple apartments for the consolidation of extended families and the maintenance of "old world" social relationships under one roof. Perhaps most importantly, Triple Deckers provided many immigrant families with the opportunity to purchase their own property for the first time by pooling their financial resources.

The first step to determine your building's construction date should be to call your local library, planning office, or the Connecticut Historical Commission in Hartford. The building's date may have already been included as part of the state's ongoing architectural survey program. If the building has not yet been "surveyed," the following may help you make your own assessment.

There are three dating methods commonly used by professional researchers. The first involves tracing the history of the property using city directories, land records, tax records, and building department records kept on file by the city. Another approach is to look through old maps of your city which were compiled in different years and which have buildings drawn on them. For example, assume you have maps for your city from 1895 and 1911. If your building is not on the 1895 map but is on the 1911 map, it is fair to assume your building was built between these two dates. A third method is to date your building on the basis of its architectural style. The three methods may be combined to arrive at the most accurate date.

#### WHAT STYLE IS IT?

Stylistic terms are used to categorize the basic massing forms and ornamental features which visually distinguish a building as a product of its time. Since Triple Deckers as a group share the same basic form, their architectural "style" is conveyed primarily through exterior ornamentation, most of which is usually found on the front of the building. Exterior ornamentation associated with Triple Deckers usually reflects the influence of one or two popular turn-of-the-century architectural styles: Queen Anne and Colonial Revival.

The Queen Anne style was very popular across the country from the early 1880s through the first few years of the twentieth century. Typical Queen Anne-style features found on Triple Deckers include different types of siding materials which create interesting patterns and textures (usually horizontal clapboards and decorative wood shingles); prominent scroll-sawn brackets under the roof eaves; elaborately detailed porches with turned posts and balusters; and large arched openings with turned or carved decorative elements.

The Colonial Revival-style ornamentation which began to appear on Triple Decker fronts in the late 1890s was less exuberant and fanciful than that of the Queen Anne style. Different siding materials gave way to uniform clapboarding on all exterior wall surfaces; elaborate turned porch and railing posts were replaced by plain columns, piers, and solid or picket railings; and scroll-sawn eave brackets were eliminated entirely or supplanted by more refined and "formal" box-like modillion brackets.

When dating a Triple Decker on the basis of architectural style, the following guidelines can generally be applied.

1. Predominantly Queen Anne-style ornamentation: late 1880s -1900.
2. Predominantly Colonial Revival-style ornamentation: 1900 - 1920s.
3. Significant combination of elements from both styles: 1895 -1910.

TYPICAL TRIPLE DECKER

FLOOR PLAN

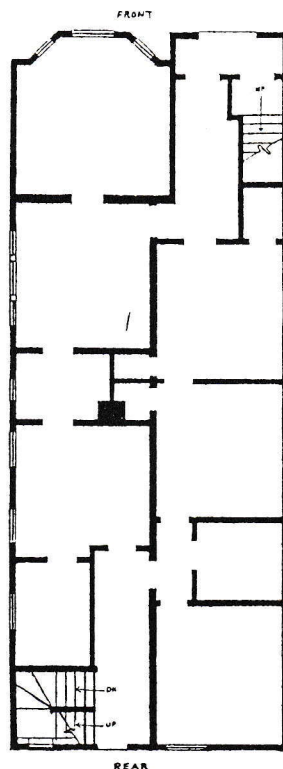

#### WHEN WAS IT BUILT?

Determining the approximate or actual age of a building can be important. If you know your building's date, a little further research will enable you to determine the physical properties of materials commonly used in the building. This knowledge can prevent you from making costly repairs with inappropriate modern materials.



QUEEN ANNE ~ STYLE "PERFECT SIX"

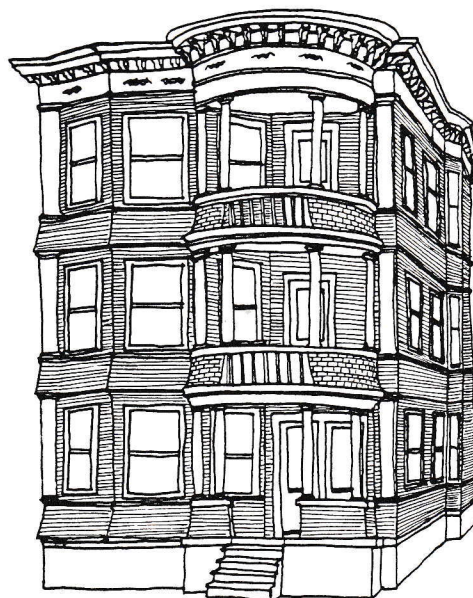

COLONIAL REVIVAL ~ STYLE TRIPLE DECKER

## MAINTENANCE AND REHABILITATION

Proper maintenance is essential to the long-term appearance, usefulness and value of any property. For Triple Deckers, which have already been exposed to the ravages of time and weather for 70 years or more, maintenance is particularly critical.

There are two basic approaches to building maintenance: reactive and preventive. In the reactive approach, minor repairs are put off until they have developed into major problems requiring immediate attention and major expense. Preventive maintenance, on the other hand, is designed to monitor the on-going maintenance needs of a building by regularly identifying and repairing minor problems, thereby minimizing the need for major repairs and expenses in the future.

The most important diagnostic component of a good preventive maintenance program is the periodic "physical." The basic tools needed to conduct such a checkup consist of a notebook and pencil (to record your observations), a penknife (to scrape and poke with), a flashlight (to help you see in poorly lit areas) and, if available, binoculars (to examine upper story walls and roofs from ground level). You can make your building's physical as detailed as you like. However, at a minimum, you should include an inspection of the following areas at least once each year:

### THE "BUILDING PHYSICAL": WHAT TO LOOK FOR

#### Exterior -

**Roof:** tears; cracks; surface bubbling; warped, cupped, missing shingles, or similar deterioration; cracks, holes, or other signs of flashing deterioration around chimneys, vent pipes, etc.

**Masonry walls (including foundations):** missing or deteriorating mortar; cracked or spalling bricks; excessive bowing or cracking of wall surface; displacement of masonry materials.

**Wooden sidings:** loose, split, rotted, or warped shingles, clapboards or trim; blistering, peeling, or cracked paint; mildew on paint surface.

**Gutters and downspouts:** damaged or missing sections; blockages caused by accumulation of debris (such as leaves); displacement.

**Chimneys:** deterioration of mortar or bricks; cracking; excessive leaning.

**Windows and doors:** debris (such as dirt or leaves) along sills which may lead to mildew or wood rot; lack of weatherstripping and caulking; rot, mold, or mildew on wood; broken sash weight cords; deteriorating glazing putty; loose or broken glass; blistered, peeling, or cracked paint on sash or casings.

**Porches and steps:** rot, mold, or mildew on wood surfaces; broken railings, floorboards, or stair treads; blistering, peeling, or cracked paint; excessive settlement of porch base or columns.

**Yard plantings:** excessive overgrowth of trees and shrubs along sides of building; creeping vines on masonry surfaces; growth of fungus and moss in damp areas.

#### Interior -

**Walls, ceilings, and trim:** water stains or streaks which may indicate leakage; buckled plaster or wall-paper; buckled floor boards; misaligned door and window frames; blistering or cracking paint.

**Attics:** water stains on rafters and floorboards or around chimneys, vent pipes, etc. which may indicate leakage; insect damage.

**Basement:** water stains or puddles which may indicate leakage; extensive condensation on walls; mold or mildew along joists and sills which may indicate excessive moisture levels; excessive bowing or cracking of foundation walls; signs of termites or similar insect infestations; cracked or severely deflecting structural members.

Once you have established your systematic review program and identified necessary repairs, you are ready to tackle rehabilitation.

The extent and complexity of the work involved in rehabilitating any building depend on a variety of interrelated factors, including the overall condition of the building, its projected use, the financial resources of its owner, and the owner's physical and technical abilities. In this brief brochure, providing a detailed description of the full range of repair problems and solutions associated with Triple Deckers would be impossible. For detailed and comprehensive information on repair techniques, check one or more of the publications listed at the end of the brochure. However, whether you are completely renovating or simply interested in limited repairs, the following information will help you get started.

#### REHABILITATION: SOME GENERAL GUIDELINES

(1) **Planning** - Before a hammer or saw is lifted, make sure you have determined all major repair issues, such as: work to be undertaken; how to finance it; requirements of zoning ordinances, building and fire codes; work you can do on your own; and work to be done by professional contractors. Thorough planning greatly helps in minimizing the risk of unanticipated expenses.

(2) **Prioritizing** - List the necessary repairs in descending order of importance and schedule your work accordingly.

(3) **Preserving** - Try to retain or restore those architectural features which visually define the building's historic character. Triple Deckers which retain original architectural features are more visually appealing, valuable, and marketable than those which do not.

(4) **Performing** - When performing repairs, always:  
(a) Use quality materials which do not damage or deteriorate easily. Inexpensive materials will usually lead to more extensive future maintenance costs.  
(b) Know your limitations. Even the most avid "do-it-yourselfer" has limited technical skills and physical abilities. Do not attempt to make repairs that exceed these limits. It could not only wind up costing you more money; but it could also lead to dangerous accidents.

#### REHABILITATION: POSSIBLE PROBLEMS, CAUSES, REMEDIES

##### (1) Paint Deterioration -

On wall surfaces, blistering and peeling often result from either a buildup of excessive moisture within the wall cavity behind the paint or from using an incompatible paint type. For example, if oil paint is applied over latex, peeling of the top coat can sometimes result. Some possible remedies which may help to alleviate moisture problems include: repairing leaky roofs; repairing and sealing walls and floors in damp basements to reduce or eliminate moisture penetration into wall cavities from this source; painting or wallpapering interior sides of the affected walls with products designed to act as vapor barriers; and, in extreme cases, installing a system of louvered wall plugs designed to vent exterior wall cavities through natural convection. Once the problem has been remedied, the affected area should be thoroughly cleaned, scraped and/or sanded; painted with a high-quality oil-based primer; and repainted with latex or oil paint according to the manufacturer's specifications.

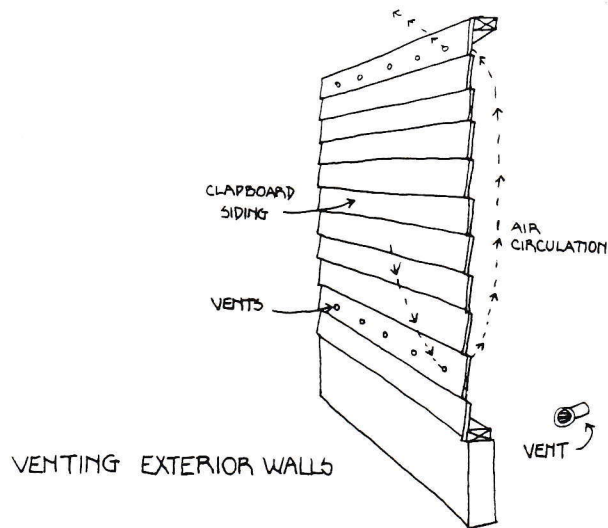

Excessive cracking of surface paint is usually caused by improper application techniques, such as painting a surface which is dirty or greasy or painting when it is too cold or damp. Cracking can also result when paint that is several layers thick becomes excessively hard and brittle with age and is no longer able to expand and contract with the wood siding in response to temperature and humidity changes. Cracking can usually be dealt with by thoroughly cleaning and carefully sanding the affected area, removing sanding residue, and repainting under weather conditions specified by the manufacturer. Remember, sanding should either be done by hand or with an orbital or reciprocating power tool. Avoid using rotary sanders; they can dig into the wood and leave marks which remain visible after painting. Stripping old paint completely should only be undertaken when the problem is extreme. If stripping is necessary, avoid using blowtorches, chemical strippers and abrasive methods such as sandblasting. These methods can cause severe damage to the siding. Paint should be removed by hand with a wide putty knife or scraper and heat plates or guns designed for this purpose. When using this method, **always** take adequate precautions against fire and toxic fumes.

For mildew problems, trim back trees or shrubs which may be inhibiting the evaporation process and/or repair leaky gutter systems. To remove mildew, scrub the affected area with a soft brush and a solution containing a cup of non-ammoniated detergent, a quart of household bleach, and a gallon of water (for stubborn spots, use an extra quart of bleach). Once the mildew is removed, thoroughly rinse the siding with a direct stream of water from a spray nozzle. After the surface is completely dry, repaint with primer and paint which are designed to be "mildew resistant."

## (2) Wood Sidings -

Splitting, warping, and rotting of wood sidings can be caused by a variety of factors, including excessive moisture levels within wall cavities, excessive weathering due to lack of paint, or the use of poor-quality materials. A buildup of mildew or mold on siding surfaces is often caused by leaky gutters or plantings which reduce air circulation along a wall.

Split clapboards can often be repaired by gently spreading the two edges of the split slightly apart, applying wood glue along each edge, and then forcing the two edges back together. The two sections can be held in place with finishing nails set above and below the split. After the glue has completely dried, remove the finishing nails, fill the holes with wood putty, and lightly sand the area smooth prior to priming and repainting.

Warped clapboards can be straightened by drilling several holes through the board and inserting wood screws. Then tighten the screws until the warp flattens out. **Caution:** to avoid splitting the board, always tighten the screws in gradual stages over a period of several days. Wet the board as thoroughly as possible prior to tightening the screws. Putty over the screws and sand the surface until smooth before repainting.

For rotted or damaged clapboards, make a vertical cut on each side of the affected section with a small saw. Using a hammer and chisel, pull the nails which hold the top and bottom of the section in place and remove the section in pieces. Replace the section with a new piece, fill any joints with wood putty, and lightly sand the joints smooth before priming and repainting.

Rotted, cracked, or warped wood shingles can be replaced on an individual basis in a similar manner outlined for clapboards, except there is no need for making cuts with a saw.

## (3) Masonry -

Most mortar deterioration results from the combined effects of weathering and air pollution. Excessive spalling and cracking of bricks usually result from the combined effects of deteriorated mortar or improper repointing. Water gets inside cracks and joints. It expands and contracts with temperature changes, cracking and displacing the surrounding masonry. Air pollution contributes greatly to the buildup of dirt and deposits on brick wall surfaces. Mixed with water, these deposits often stain brick.

Deteriorated mortar should be repointed. Loose mortar should be removed from the affected area by hand with a hammer and chisel to a uniform depth of 1/2-1". To ensure a good bond, flush chiseled joints with water

## REPAIRING CLAPBOARDS



CRACKED CLAPBOARDS

- GLUE CRACK
- NAIL CLOSED

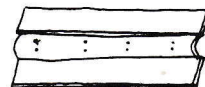

WARPING CLAPBOARD

- SCREW FLAT AT SLOW INTERVALS



REPLACING DAMAGED CLAPBOARD

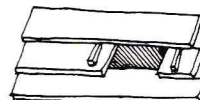

- SAW EITHER SIDE OF DAMAGED SECTION
- INSERT WEDGES AND REMOVE DAMAGED PIECES

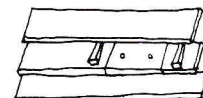

- NEW SECTION CUT TO SIZE AND GLUED OR SCREWED IN PLACE
- JOINTS ARE FILLED AND SANDED, THEN PAINTED
- WEDGES REMOVED

prior to refilling them with new mortar. **Important Precautions:** When removing old mortar, do not chip the edges of the surrounding bricks. This will accelerate the deterioration of the brick. Make sure that new mortar matches the color and composition of the original mortar. Most older buildings have bricks designed for use with soft lime mortar; hard cement-based mortars can eventually damage the surrounding bricks. If you are unsure of the type of mortar to use, have some of the original analyzed at a high school or college chemistry laboratory to determine the proper mix. Finally, never refill a joint completely; finished joints should always be slightly recessed.

Minor cracks in bricks can usually be repaired by filling them with tinted sealant designed for that purpose. Severely cracked, broken, or spalling bricks should be replaced by chiseling out the damaged brick and surrounding mortar, laying a shallow mortar bed on the bottom, top, and sides of the cavity, and inserting a brick "battered" on all but the finish side with mortar prior to final pointing. The new brick should match the original brick as closely as possible in size, color, and texture.

Proper removal of dirt deposits from brick can be accomplished in two ways: (a) hand scrubbing with soft bristled brushes and rinsing with water sprayed under low to moderate pressure; and b) chemical cleaning. Chemical cleaning is a highly technical and potentially dangerous procedure which should be undertaken only by competent and knowledgeable professionals. **Never** utilize abrasive cleaning methods such as sandblasting on exterior brick. They can irreparably damage brick. Also, never coat brick with clear "waterproof" sealants such as silicone. It is an unnecessary expense which can result in major maintenance problems in the future if moisture gets trapped beneath the sealant.

#### (4) Roofs -

Exposure to rain, sunlight, and air pollution will eventually lead to the deterioration of roof surfacing and flashing materials and leakage. Your first step toward curing these problems should be to assess the existing condition of the roof. (You may want to contact a reputable roofing contractor to help with this.) If deterioration is extensive, replacement may prove more effective and economical than piecemeal patching. However, under certain circumstances, patching can be useful and cost-effective. For example, as a **temporary** measure, existing leaks should be repaired immediately to prevent water damage in the rest of the building until the new roof is installed.

For roof systems in which the bulk of the surface fabric and/or flashing is essentially sound, selective repair can often provide new life to an older roof at moderate cost. For example, assume that the asphalt roll roofing of a Triple Decker is in good condition. However, the metal flashing at the juncture of the chimney stack and roof has deteriorated, and a leak has developed. Sometimes this problem can be cured by carefully raising the sections of roofing immediately around the stack, carefully pulling out the old flashing, and installing new flashing under the roll roofing, which is then resealed.

#### (5) Energy Conservation -

Excessive infiltration (flow of air into and out of a building), inefficient heating/cooling systems, and lack of insulation are among the most typical reasons for high heating and cooling costs.

Excessive infiltration can account for 40 percent of the heating and cooling costs of older buildings. To reduce infiltration, make sure that all door and window openings are properly weatherstripped and caulked. Storm windows and doors should be installed and functioning properly. Cracks and crevices along foundation walls (especially where they meet wooden sills) should be sealed with appropriate caulking materials.

Like infiltration, inefficient heating/cooling systems are a leading cause of high energy costs in older buildings. Have your system serviced at least once a year to ensure peak operating efficiency. Consider upgrading old heating equipment with more efficient units. Automatic thermostats which lower temperature levels when a building is vacant are also helpful. On days which are not too hot, turn air conditioners off and open the windows instead; Triple Decker windows usually provide good cross-ventilation.

#### REPOINTING: REMOVING OLD MORTAR

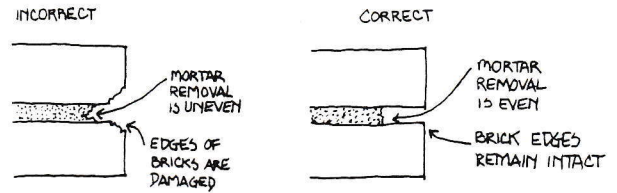

#### REPLACING A DAMAGED BRICK

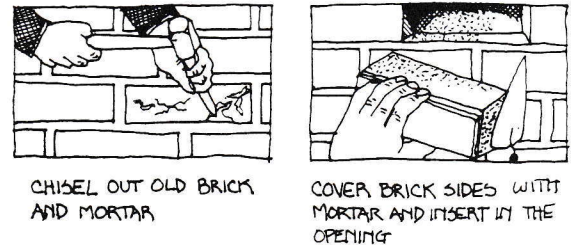

Most owners today recognize the potential benefits of insulated walls and roofs. However, many are unaware of the potential dangers posed by improperly installing insulation, especially in older buildings.

A safe and effective way to insulate a side wall with interior wall surfaces that are already in need of replacement is to remove the interior wall surface, install fiberglass batt insulation between the exposed studs, cover it with an appropriate vapor barrier material such as polyfilm, and install a new interior finish surface directly over the vapor barrier.

In order to avoid ripping out plaster, many property owners decide to have insulation blown into the wall cavities. Be careful! Blown-in insulation techniques rarely include provisions for effective vapor barriers. Without them, when warm water vapor from the interior comes in contact with cold insulation during the winter, it will condense into water. The result is soggy and ineffective insulation. Since air cannot circulate through the wall, moisture may become trapped and cause rot in the walls or peeling exterior paint.

Remember, if you are going to go to the trouble and expense of insulating, make sure it is done right. Otherwise you may spend a lot and gain little.

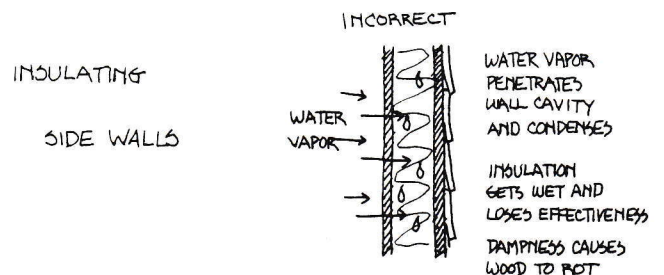

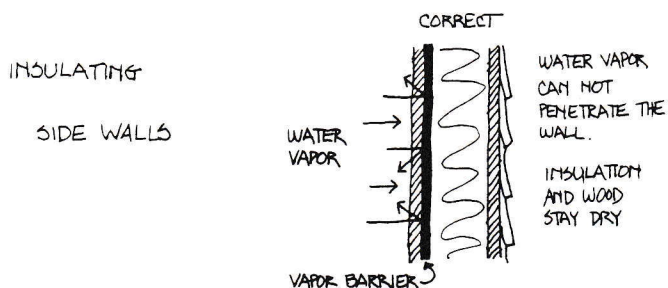

### (6) Exterior Paint Color -

From a visual standpoint, exterior paint color is one of the most important character-defining features of a building. Often, well-intentioned owners who have worked hard to repair, replace, or retain historic exterior trim or siding materials on a Triple Decker realize too late that the new paint color scheme they have used is inappropriate for one or more of the following reasons: too many colors were used; not enough colors were used; the colors chosen are from the wrong historical era.

You can usually avoid this problem if you take the following steps. First, try to determine the original color scheme of the building. Carefully scrape off the paint along the edges of sidings and trim features at several locations on the **north** side of the building until the bottom paint layer is exposed. When scraping, angle your knife slightly; this will help make the color of each layer of paint more visible. Then wet the scraped area; this will allow you to determine the original base color more accurately.

If this method proves unsuccessful, or you do not like the particular color scheme you have uncovered, consult publications which describe appropriate color schemes for the period in which your building was built. You can also refer to charts published by various paint manufacturers which describe documented historic colors and color schemes. Since some of these publications can be expensive to purchase, you may want to call a local or state historic preservation organization. Often, these organizations keep such information on file as a public service. These groups can also provide invaluable assistance if you have questions or want further guidance.

### (7) Exterior Trim -

Like paint color, moldings, brackets, porches, and other ornamental trim features give special character to the exterior of a building. Whether you do the work yourself or have it done, retaining, repairing, or replacing these features will be a worthwhile investment in the total value of your property.

For loose trim features such as moldings, carefully refasten the feature by drilling holes and countersinking and screwing the trim back on. Before scraping and repainting, fill the screw hole depression with putty and sand lightly.

Epoxies, polyesters, and synthetic resins available on the market today often allow for repair rather than

replacement of partially rotted or broken features such as porch posts and railings. With the use of such materials, rotted sections can often be cut out and refilled; and broken or cracked brackets, balusters, moldings, doors, and other wooden features can often be reglued. Features beyond repair can be reproduced with a jig or sabre saw and drill and stock lumber, using an intact, similar feature as a model. Intricate features such as brackets can often be made in sections and then glued together with waterproof epoxies. If exact reproduction of a feature such as a molding is not possible, approximate the size and shape of the original as closely as you can. If a major feature such as a front porch is missing entirely, try to locate an old photograph on which to base the design of the new porch. If you cannot find a photograph, look at similar nearby buildings which retain old porches; these may help to give you an idea of the size, shape, and details of the porch which was removed from your own building.

### DUPLICATING A BRACKET

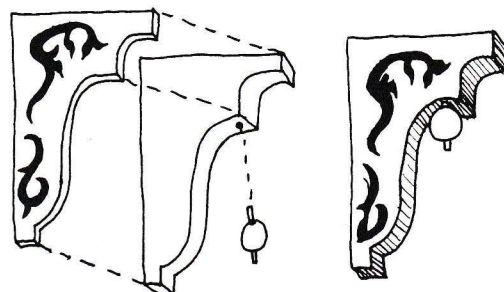

PLYWOOD CUT-OUT WITH FLORAL DESIGN IS APPLIED TO BRACKET BLOCK WITH GLUE

FINISHED BRACKET WITH SANDED JOINTS AND BALL PENDANT

### CORNICE DETAIL AND REPAIR

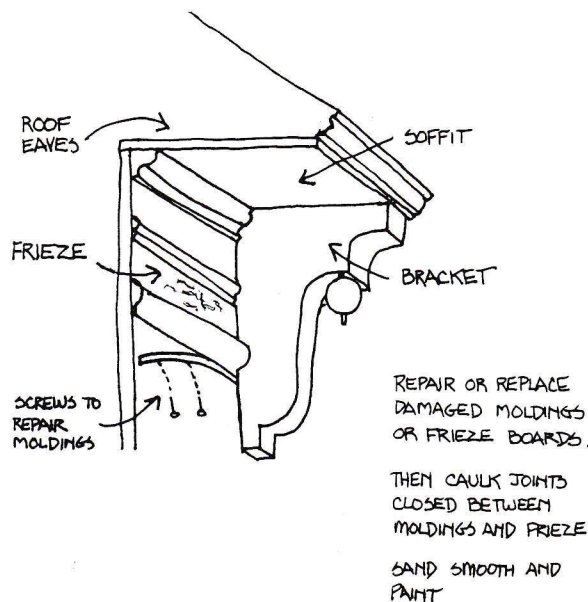

## RESOURCE PUBLICATIONS

(1) The following publications can be obtained upon request from the U.S. Superintendent of Documents, Government Printing Office, Washington, D.C. 20240. Most are available for a minimal charge.

**Condensation Problems in Your House: Prevention and Solution.** By L.O. Anderson and G.E. Sherwood, 1974.

**Principals for Protecting Wood Buildings From Decay.** By J.C. Sheffer and A.F. Verrall, 1973.

**Wood Siding: Installing, Finishing, Maintaining.** 1973.

**Preservation Brief # 1: The Cleaning and Waterproof Coating of Masonry Buildings.** By Robert C. Mack, 1977.

**Preservation Brief # 2: Repointing Mortar Joints in Historic Brick Buildings.** By Robert C. Mack, 1976.

**Preservation Brief #4: Roofing for Historic Buildings.** By Sarah M. Sweetster, 1978.

**Preservation Brief # 3: Conserving Energy in Historic Buildings.** By Baird M. Smith, 1978.

**In the Bank... Or Up the Chimney.** By U.S. Department of Housing and Urban Development, 1975.

**The Secretary of the Interior's Standards for Rehabilitation and Guidelines for Rehabilitating Historic Buildings.** 1983.

**Subterranean Termites: Their Prevention and Control in Buildings.** By H.R. Johnston, 1975.

(2) The following are privately printed publications which are available from the sources noted.

**A Field Guide to American Houses.** By Virginia and Lee McAles-ter, 1984. Available from Alfred A. Knopf, Inc. New York, NY.

**American Architecture Since 1780: A Guide to Styles.** By Marcus Whiffen, 1969. Available from The MIT Press, Massachusetts Institute of Technology, Cambridge, MA 02142.

**How to Date a House.** 1976. Available from The Old-House Journal, 69-A 7th Ave., Brooklyn, NY 11217.

**How to Date a House.** By David M. Hart, 1975. Available from the Society for the Preservation of New England Antiquities, 141 Cambridge St., Boston, MA 02114.

**The Eight Most Common Mistakes in Restoring Historic Houses.** By Morgan W. Phillips, 1975. Available from the Society for the Preservation of New England Antiquities, 141 Cambridge St., Boston MA 02114.

**Inspection Checklist for Vintage Houses.** 1977. Available from The Old-House Journal, 69-A 7th Ave., Brooklyn, NY 11217.

**Old House Woodwork Restoration.** By Ed Johnson, 1983. Available from The Old-House Journal, 69-A 7th Ave., Brooklyn, NY 11217.

**The Care of Old Buildings Today: A Practical Guide.** By Donald Insall, 1974. Available from the Preservation Bookshop, 740 Jackson Pl., N.W., Washington, DC 20006.

**How to Buy and Fix Up An Old House.** 1976. Available from Home-Tech Publications, 7315 Wisconsin Ave., Bethesda, MD 20014.

**Century of Color.** By Roger Moss. Available from J.D. Dewell and Company, 1010 State Street, New Haven, CT 06511.

**American Shelter.** By Lester Walker, 1981. Available from The Overlook Press, Lewis Hollow Road, Woodstock, NY 12498.

**Illustrated Dictionary of Historic Architecture.** Edited by Cyril M. Harris, 1977. Available from Dover Publications, 180 Varick Street, New York, NY 10014.

**Insulating the Old House.** Edited by Sally E. Nielson, 1977. Available from Greater Portland Landmarks, 165 State Street, Portland, ME 04101.

Text and drawings by Paul Loether and Preston Maynard

Published by The New Haven Preservation Trust, 1985